



MULTI-JET VANE WHEEL TYPE

Dry-dial Brass/Plastic body water meters

It is a multi-jet dry type water meter for residential application in sizes 15mm-50mm for cold / hot water.

Features

- Magnetic Drive, Lower transmission resistance.
- Magnetic shield, for external magnetic field protection.
- Sealed dry register ensures long time clear reading.
- External regulating device.

Accessories: 2pcs coupling, 2pcs coupling nuts and 2pcs washers.

Optional Features

- Register sealed type: Dry type; Semi-dry type; Super-dry type.
- Accuracy: R=80 ; 100; 125; 160.
- Size: 15~50mm.
- Cold / hot water.
- Non return valve.
- Reed switch option.
- Several lengths and connections available on request.
- Thread end type: BSP / NPT.

Maximum Permissible Error

- In the lower zone from q_{min} inclusive up to but excluding q_t is $\pm 5\%$.
- In the upper zone from q_t inclusive up to and including q_s is $\pm 2\%$; $\pm 3\%$ for hot water meter.

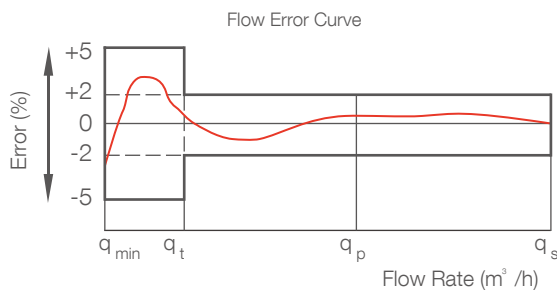

Standards Compliance

Technical data conform to international standard ISO 4064.

Working Conditions

- Water temperature: 0.1 C ~ 50 C for cold water meter.
- 0.1 C ~ 90 C for hot water meter.
- Water pressure: $\leq 1.6\text{Mpa}$ (16 bar).

Overall Dimension And Weight

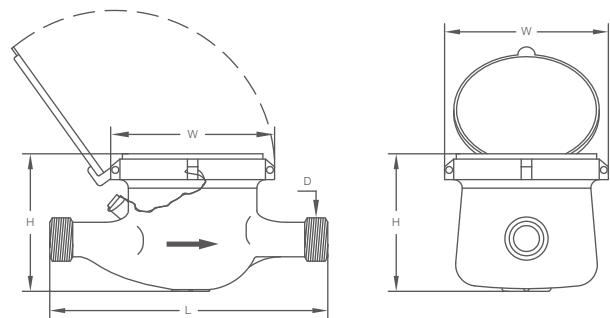

DN (mm)	15	20	25	32	40	50	50
Size (inch)	1/2"	3/4"	1"	1-1/4"	1-1/2"	2"	2"
Length (L)	165/190	190	260	260	300	300	280
Width (W)	98	98	103.5	103.5	125	125	160
Height (H)	116	117	124	124	162	162	187.5
Connecting Thread D	G3/4B	G1B	G11/4B	G11/2B	G2B	G21/2B	Flange end
Weight (kgs)	1.65	1.79	1.85	2.68	5.25	7.25	





Exploded View



Technical Data

DN (mm)	15	20	25	32	40	50	
Size (inch)	1/2"	3/4"	1"	1-1/4"	1-1/2"	2"	
Q4(l/h)	3125	5000	7875	12500	20000	31250	
Q3(l/h)	2500	4000	6300	10000	16000	25000	
R=80	Q2 (l/h)	50	80	126	200	320	400
	Q1 (l/h)	31.25	50	78.75	125	200	250
R=100	Q2 (l/h)	40	64	100.8	160	256	400
	Q1 (l/h)	25	40	63	100	160	250
R=125	Q2 (l/h)	32	51.2	80.64	128	204.8	200
	Q1 (l/h)	20	32	50.5	80	128	
R=160	Q2 (l/h)	22.5	40	63	100	160	400
	Q1 (l/h)	15.62	25	39.37	62.5	100	250
Max. Reading (m3)	99,999	99,999	99,999	99,999	99,999	99,999	
Min. Reading (Liter)	0.05	0.05	0.05	0.05	0.05	0.05	
Max. Pressure (Bar)	16	16	16	16	16	16	
Pressure Loss (Δ P)	63						
Max. Temperature	T=50 /90						
Pulse Output Option	Vmax=24V						
	Imax=100mA						
	Pmax=2W						

Pulse Output Option



Magnet Position	Liter /Pulse
* 0.0001	1
* 0.001	10
* 0.01	100
* 0.1	1000

Warranty

All meters will be guaranteed against defects in workmanship and materials for a period of one (1) year from the date of acceptance. Defective meters or parts discovered within this period shall be replaced without charge upon return to the SH-MECH Meters.