



LXHY-15~40

Rotary Piston Liquid Sealed Water Meter

This type of water meter can be used for a remote reading transmission system is equipped with a built-in sensor.

Application

Measuring the volume of cold portable water passing through the pipeline. Also suitable for pure water.

Operating Condition

- The Max. Admissible water pressure 1.6MPa.
- Resisting water temperature: 50 °C.

Features

- Low start-up flow rate.
- Volumetric rotary piston principle of measurement.
- LXHY-15 ~20 is no location limitation for installation. Accuracy is not to be affected wherever installed at a horizontal, vertical or inclined pipeline.
- Register is sealed with a special liquid to keep a clear reading in long term service.
- Mechanism use of high-quality material to ensure a stable characteristic.
- Accurate measurement with conformity to ISO 4064 class C.
- On request, the series can be equipped with a kind of remote transmission device.

Pulse Position

Magnet Position	Liter / Pulse
* 0.0001	1
*0.001	10

Note

- Body material: Brass body / Plastic body.
- Size: Plastic body: DN15-20; Brass body: DN15-40.
- Different register can be choose:

Dial Picture	Measure Unit
	Measure Unit: CBM 8 Wheels Four red, four white wheel. The minimum reading: 1L
	Measure Unit: CBM 8 Wheels Three red, five white wheel. The minimum reading: 10L
	Measure Unit: UK Gallon 8 Wheels One red, seven white wheel The minimum reading: 1 UK/Gallon
	Measure Unit: UK Gallon 8 Wheels All white wheel The minimum reading: 10 UK Gallon
	Measure Unit: US Gallon 8 Wheels One red, three black, four white wheel The minimum reading: 1 US Gallon





Dimensions

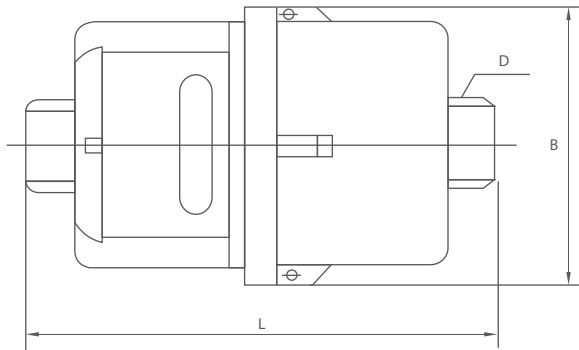

Description	Unit	Hydraulic Data And Dimensions					
		DN15 (1/2)	DN20 (3/4)	DN25 (1)	DN32 (1-1/4)	DN40 (1-1/2)	
Nominal Size	mm (inch)						
Q: Error Limit ±2%	m ³ /h	3.125	5	7.875	12.5	20	
Q: Error Limit ±2%	m ³ /h	2.5	4.0	6.3	10	16	
Q: Error Limit ±2%	l/h	25	40	63	100	160	
Q: Error Limit ±5%	l/h	15.6	25	39.4	62.5	100	
Min. Reading	l	0.05	0.05	0.05	0.5	0.5	
Max. Reading	m ³	9999.9999	9999.9999	9999.9999	99999.999	99999.999	
MAP	MPa	1.6	1.6	1.6	1.6	1.6	
Press Loss ΔP AT Q ³	MPa	≤0.063	≤0.063	≤0.063	≤0.063	≤0.063	
L	mm	195	267	319	384	428	
l	mm	115	165	199	260	300	
B	mm	43	43	53	60	77	
Weight	Without Connections	Kg	1.14	1.56	2.48	3.47	5.65
	With Connections	Kg	0.97	1.3	2.05	2.75	4.7

Maximum Permissible Error

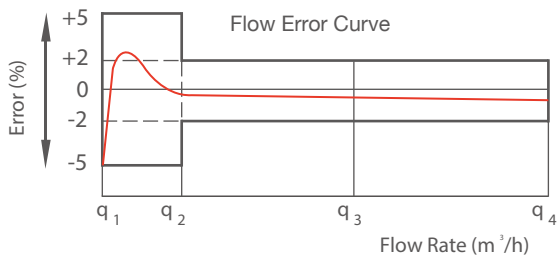

Exploded View

