

AMI SYSTEM INTRODUCTION

SIMPLE IS SMART.....

System structure diagram as follows

- server send commands to the data concentrator through network;
- concentrator transforms the received commands into radio signal and send the signal to the water meters;
- water meters respond and execute the commands accordingly;
- Water meters deliver the result or data back to the management center as per the original route after the actions finished.

Service

- Quality Gurantee: Water meter for 1 year;
- Support install guide & test in site;
- Date sheet can be sent to other management system easily.



ULTRASONIC WATER METER



Brief introduction

Ultrasonic water meter is a new type of water meter that detects the time difference caused by the change of velocity when the ultrasonic beam propagates in the opposite direction of the water, and analyzes and processes the flow rate of water to further calculate the flow of water.

Dimension

Nominal Diameter	Length L	Length L1	Width B	Height H1	Connecting Thread	
mm					d	D
15	258	165	95	95	R1/2B	G3/4B
20	299	195	95	100	R3/4	G1B
25	345	225	95	108	R1	G1 1/4B
32	305	180	95	120	R1 1/4	G1 1/2B
40	330	200	95	125	R1 1/2	G2B

Benefits

- No mechanical movable parts , Impurities in water can't be affected, long service life.
- Wide measurement range. Very small flow can be measured.
- Various alarm functions : Battery voltage can alarm 、 empty tubes or pipes that are not full of water 、 transducer fault alarm and more.
- Low-power design and the use of high-energy batteries, can work for 8 years and more.
- The communication interface is Lora or Rs485, can achieve remote real-time monitoring and management on the LAN.

Technical specifications

Item	Unit	Details				
Nominal diameter	mm	15	20	25	32	40
Q3/Q1		R200				
Overload flow(Q4)	m ³ /h	3.125	5	7.875	12.5	20
Nominal flow(Q3)	m ³ /h	2.5	4	6.3	10	16
Transitional flow(Q2)	m ³ /h	0.02	0.032	0.05	0.08	0.128
Minimum flow(Q1)	m ³ /h	0.013	0.02	0.032	0.05	0.08
Accuracy class		Class 2				
Battery life		8years				
Temperature class		T30/T50				
Pressure class		≤0.063Mpa				
Pressure loss class		ΔP63				
Flow profile sensitivity class		U10/D5				
Environmental class		Class B,M1				
Electromagnetic environment class		E1				
Working pressure		1.6Mpa				
Max flow indication		999999.9m3				
Installation position		Horizontal or Vertical				

Outline dimensional drawing

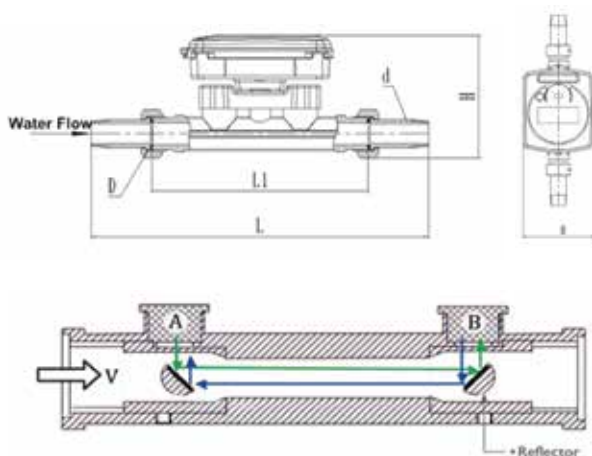

BULK ULTRASONIC WATER METER



Overview

- Ultrasonic water meter's intelligent measuring instrument is consist by the temperature sensor , flow sensors and calculators.
- Could provide important application and data for many applications in the pipeline.
- Ultrasonic water meter is suitable for application environments requiring high range ratio (Q3/Q1) and forward and reverse metering.
- Calculator used sensor and through the time difference to collect temperature differences and sound waves to complete accurate measurement of water flow. And can provide important application and data for many applications.

Working principle

The meter comprises the quality temperature sensor ,the flow sensor and the calculator. The temperature sensor to measure the temperature of water and the flow sensor to measure the volume of water that flow through the pipelines by the transit time difference. The two data is sent to the calculator after being collected, the consumption water quantity is worked out, stored and indicated on the LCD finally.

Outline dimensional drawing

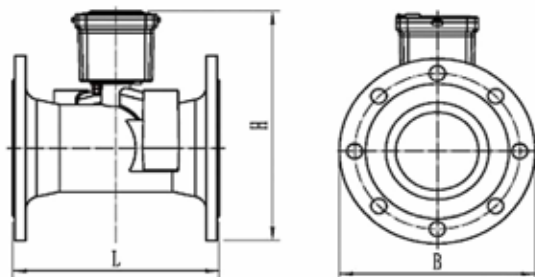

Outline dimension

Nominal Diameter	Length L	Width B	Height H	Flange Connection		
				Flange Diameter	Bolt Circle Diameter	Bolt Size-M
mm						
DN50	200	170	215	170	125	4-M16
DN65	200	185	220	185	145	4-M16
DN80	225	200	235	200	160	8-M16
DN100	250	220	255	220	180	8-M16
DN125	250	250	285	250	210	8-M16
DN150	300	285	335	285	240	8-M20
DN200	350	340	405	340	295	12-M20
DN250	450	405	470	405	355	12-M24
DN300	500	460	525	460	410	12-M24

Technical parameter

Nominal diameter(mm)	50	65	80	100	125	150	200	250	300
Max flow Q4(m ³ /h)	50	78.75	78.75	125	200	312.5	500	787.5	1250
Nominal flow Q3(m ³ /h)	40	63	63	100	160	250	400	630	1000
Transitional flow Q2(m ³ /h)	0.16	0.756	0.252	0.4	0.64	1	1.6	2.52	4
Min flow Q1(m ³ /h)	0.1	0.158	0.158	0.25	0.4	0.625	1	1.575	2.5
Protection class	IP68								
Measuring range	Q3/Q1 R250/R400								
Accuracy class	Class 2								
Battery life	8 years								
Temperature class	T50								
Pressure loss class	ΔP63								
Flow profile sensitivity class	U10/D5								
Environmental class	Class B,M1								
Electromagnetic environment class	E1								
Working pressure	1.6Mpa								
Max flow indication(m ³)	9999999.9								
Reverse flow indication(m ³)	9999999.9								
Installation position	Horizontal or Vertical								

NOTE: The flange dimension conforms to ISO7005-1:1988 standard. Flange standard can be customized. Order for products of special requirements is also accepted.